DYNAMIC FUZZY LOGIC FUNCTOR

J. L. Pérez-Silva, A. Garcés-Madrigal, A. Miranda-Vitela, F. Lara-Rosano.

Centro de Ciencias Aplicadas y Desarrollo Tecnológico
Universidad Nacional Autónoma de México
pepito@aleph.ccadet.unam.mx

ABSTRACT

This is a fuzzy logical element from which we can generate all the fuzzy connectives as particular cases of it. This functor was a result of the frequency threshold dependent fuzzy logic. We will show that fuzzy logic connectives are generated by a defined group of inputs from this fuzzy functor as dependence of frequency threshold. If we apply time varying signals to the functor, we will see that the responses of the functor depend on the concordances of the input signals and the frequency threshold value. The value of the logical functor threshold can be a time dependent function in such a way that, when varying the threshold, the form that the functor takes as logical connective changes for each time dependent threshold function value in time. In this work we will define the logical functor, we will show its logical operation procedure and we will show the electronic circuit in which a functional model was implanted.

RESUMEN

Este es un elemento lógico borroso a partir del cual podemos generar todos los conectivos lógicos borrosos como casos particulares de él. Mostraremos que los conectivos de la lógica borrosa se generan, para un conjunto definido de entradas, a partir de este functor borroso como una dependencia del umbral de frecuencia. Si al functor le aplicamos señales variantes en el tiempo veremos que las respuestas del functor dependen de las concordancias de las señales de entrada con el valor del umbral de frecuencias. El valor de umbral del functor lógico puede ser una función dependiente del tiempo de forma tal que, al variar el umbral, la forma que cobra el functor como conectivo lógico está cambiando para cada valor de la función temporal del umbral en el tiempo. En este trabajo definiremos al functor lógico, mostraremos su forma de operación lógica y mostraremos el circuito electrónico en el que se implantó un modelo funcional.

KEY WORDS: Logic functors, dynamic fuzzy logic, threshold dependent fuzzy logic.

1. INTRODUCTION

In the syntax of fuzzy logic, "P" and "Q" will have values in the closed interval {0, 1}, and "P" "Q",..., will be meanings by the value of the propositional variable. The connectives valuation is defined as:

$$\begin{aligned} |\neg P| &= 1 - |P|, |P \wedge Q| = \min (P_1|Q_1), \\ |P \vee Q| &= \max (P_1|Q_1), \\ |P \rightarrow Q| &= 1 \text{ if } |P| \leq |Q| \end{aligned}$$

We can define in fuzzy logic the semantic linking in the way:

$$P \rightarrow Q \text{ if } |P| \leq |Q|,$$

it means: Be $P = \text{John is very tall}$ and $Q = \text{John is tall}$. Clearly P links semantically Q since the value of very high is smaller or similar to high. " \rightarrow " It is the material implication logical correlative that will be valid in fuzzy logic in all the cases where one has a real logical implication among " P ", " Q ", this is that: $P \leq Q$ is necessary.

$$P \rightarrow P, \text{ and } \neg P \vee P,$$

are tautologies in fuzzy logic.

Let us suppose that: $P = \text{this wall is red}$. Let us suppose that the wall is really 0.6 red, then: " $\text{The wall is red or not}$ " is really certain in 60%, according to the given semantics. Similarly: $P \wedge \neg P$ is not a contradiction, since their value is really 40%. From the point of view of the fuzzy logic the modus ponens is not only the inference principle but rather we can generalize it in such a way that it really preserves the truth grade:

$$\begin{array}{l} | \neg_{\alpha} P \\ P \rightarrow Q \\ \therefore | \neg_{\alpha} \rightarrow Q \end{array}$$

If we consider P certain in α grade, and we know that $P \rightarrow Q$, then we can be sure that Q is certain in α grade. The design of elements that operate as fuzzy logical gates carrying out the operations of

$$|P \wedge Q| = \min(|P|, |Q|), \text{ and } |P \vee Q| = \max(|P|, |Q|) \text{ exists.}$$

In this work, a new idea that it is based on the fuzzy neurons models with synapses V/F-F/V that we have denominated time dependent Fuzzy Logic Functor is presented.

We develop a system that is only based on a single logical gate that is the fuzzy logical functor. This is a fuzzy logical gate from which we can generate all the fuzzy logical connectives as particular cases of it. This functor is an immediate result of the frequency threshold dependent fuzzy logic. We will show that fuzzy logic connectives are generated for a defined input set, starting from this fuzzy functor as frequency threshold dependence of the neuronal model. If we apply time varying signals to the functor, we will see that the responses of the functor depend on the concordances of the input signals and the frequency threshold value. The threshold value of the logical functor can be a time dependent function in such a way that, when varying the threshold, the form that the functor takes, as logical connective, changes for each value of the temporary threshold function in time. This way, for inputs that do not vary in time, we can go from having a conjunction, to a disjunction, to an implication, or to always on, or to always off, like basic tautological forms, as time function. In this work we will define the logical functor; we will show its logical operation form and the electronic circuit in which a functional model was implanted.

2. CIRCUIT DESCRIPTION

The functional blocks with which this circuit operates are the following ones: maxima and minima selectors.

This circuit operates according to the following logic: given a circuit input, the set of maxima and minima of this is selected, according to a fixed or a variable reference value. In simultaneous manner, a ramp is generated; as time advances, it produces a lineal transition of states (0, 1,2,...), which are logically

operated in such a way that it selects the output value that corresponds to that state, one per time, of four possible output values: the original signal, the minimum signal values, the maximum signal values, or a null signal output .

The maxima and minima detecting circuit operates in the following way: consider the amplifier of figure 1 which operates with the reference signal connected to the negative input of the amplifier and the signal we want their maxima or minima to detect, connected to the positive input of the same one.

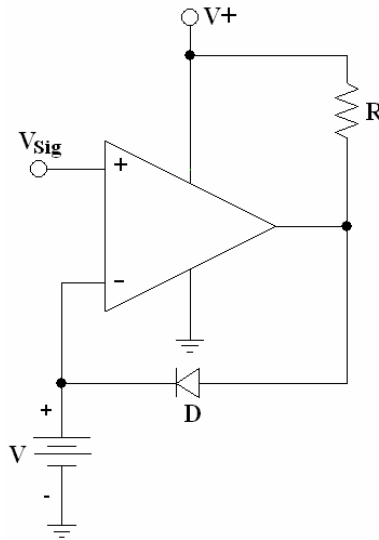

Figure 1. Maxima detecting Circuit.

the voltage in the diode is given for:

$$Y_D = (V_{out} - (V-))$$

if the diode D is in cut:

$$(V_{out} - (V-)) < 0 \tag{1}$$

As the amplifier operates in open loop we have:

$$V_{out} = ((V+) - (V-))G \tag{2}$$

Where G is the open loop gain. Substituting (2) in (1)

$$\begin{aligned} ((V+) - (V-))G - (V-) < 0 \\ (V+) - (V-) - ((V-)/G) < 0 \end{aligned} \tag{3}$$

as

$$G \gg V-$$

and

$$V+ < V-$$

this is, D is off and the output is similar to the reference value in V-. If D is on:

$$V_{out} - V- \geq 0$$

For an equivalent reasoning we have:

$$V+ < V- \tag{4}$$

and as the amplifier operates in closed loop:

$$((V+) - (V-)) = 0 \tag{5}$$

For (4) and (5) are satisfied simultaneously, we have that the output is fixed to the values of V+ and, therefore, the circuit operates as a bigger values detector to a given reference value.

The detecting circuit of minima operates in the following way: consider the amplifier of figure 2 which operates with the reference signal connected to the negative input of the amplifier and the signal to detect their minima connected to the positive entrance of the same one.

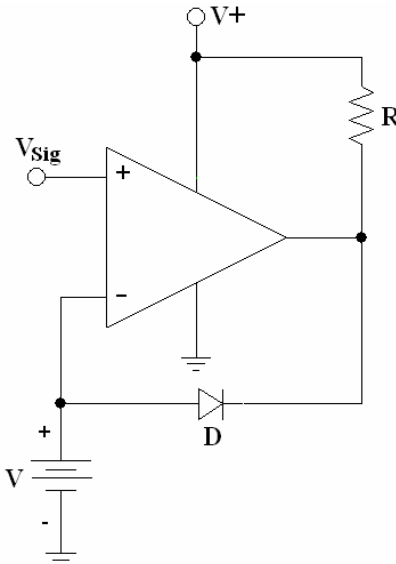

Figure 2. Minima detecting circuit.

The voltage through the diode is given for:

$$V_D = (V-) - V_{out}$$

If the diode is in cut:

$$(V-) - (V_{out}) \leq 0 \tag{6}$$

As the amplifier operates in open loop we have:

$$V_{out} = ((V+) - (V-))G \tag{7}$$

Where G is the open loop gain:

Substituting (7) in (6)

$$\begin{aligned} (V-) - ((V+) - (V-))G &< 0 \\ ((V-) / G) - (V+) - (V-) &< 0 \end{aligned} \tag{8}$$

as

$$\begin{aligned} G &\gg (V-) \\ (V-) &< V+ \end{aligned}$$

D is off, and the output is similar to the reference value in V-

If D this on:

$$(V-) - V_{out} \geq 0.$$

We have for an equivalent reasoning that:

$$V- \geq V+ \tag{9}$$

as the amplifier operates in closed loop:

$$((V+) - (V-)) = 0 \tag{10}$$

If (9) and (10) are satisfied simultaneously, we have that the output is fixed to values of V+ and, therefore, the circuit operates as a smaller values detector to a given reference value.

This is a functor if we have the following values:

F(t)=mt	Salida
0 Vcc	Original signal
1/3 Vcc	Minimum value of the signal
2/3 Vcc	Maximum value of the signal
3/3 Vcc	Null output

The output of these circuits for a senoidal signal and a given reference value are shown in Figure 3.

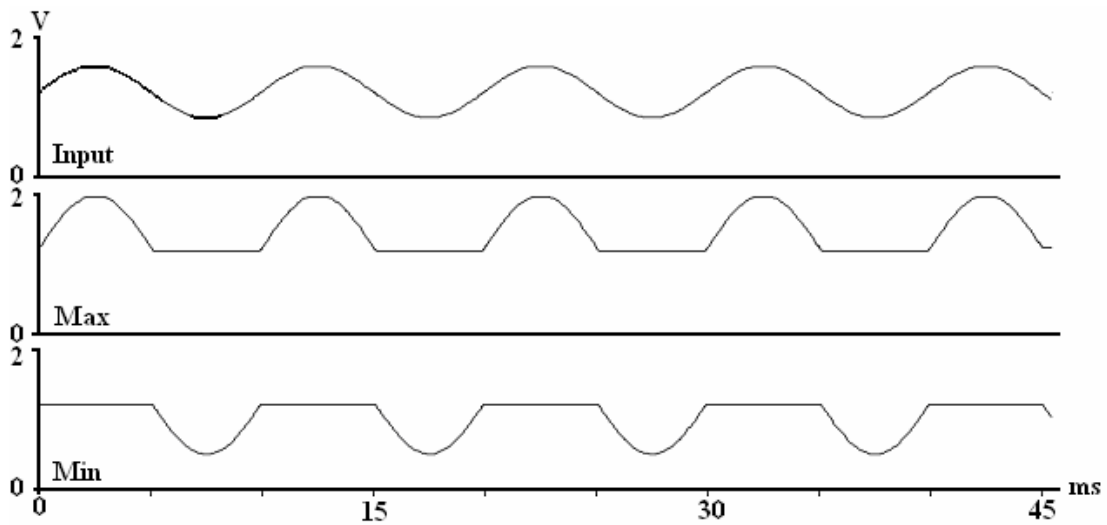

Figure 3. Selection of maxima and minima with respect to an arbitrary signal of reference.

3. DYNAMICS FUZZY LOGIC

From the dynamic fuzzy sets published by the authors^[1], we extend the fuzzy logic to a dynamic fuzzy logic. The valuation of connectives is defined as:

$$\begin{aligned} |\neg P(t)|^T &= 1 - |P(t)|, \\ |P(t) \wedge Q(t)|^T &= \min(|P(t)|, |Q(t)|) \forall t, \\ |P(t) \vee Q(t)|^T &= \max(|P(t)|, |Q(t)|) \text{ in any time} \end{aligned}$$

In dynamic fuzzy logic we can define the dynamic fuzzy link in the following way:

$$|P(t)|^T \rightarrow |Q(t)|^T \text{ if } |P(T)| \leq |Q(T)|$$

it means: be $P(t)$ = John is very tall in time t and $Q(t)$ = John is tall in time t . Clearly, $P(t)$ links $Q(t)$ semantically, since in time t the value of very tall is smaller or similar to tall, but in another time this doesn't have to be this way.

In dynamic fuzzy logic we say:

$$|P(t)|^T \rightarrow |P(t)|^T \forall t$$

and

$$|\neg P(t) \wedge P(t)|^T \forall t$$

are tautologies at all time too.

Let us suppose that: P = this wall is red in time t . Let us suppose that the wall is really 0.6 red in time t , then "the wall is red or not in time t " is really certain in 60% in that time t , according to the given semantics.

Similarly:

$$|\neg P(t) \wedge P(t)|^T$$

is not a contradiction since their value is really 40% in time t .

If we consider P certain in α grade, and we know that $P \xrightarrow{T} Q$, then we can be sure that Q is certain in α grade at this time. In dynamic fuzzy logic:

$$\begin{aligned} |^T -_{\alpha} P(t)|, \\ |P(t) \rightarrow P(t)|^T, \\ \therefore |^T -_{\alpha} Q(t)| \end{aligned}$$

Then we can generalize our functor to a dynamic fuzzy logic functor if we add the following elements to the system: time dependent membership function generator, and output selection logic

4. OUTPUT SELECTION LOGIC

As a time dependent membership function generator, a ramp signal that commutes the selection of the output according to the value and time that this signal points to is generated. We show the circuit in Figure 4.

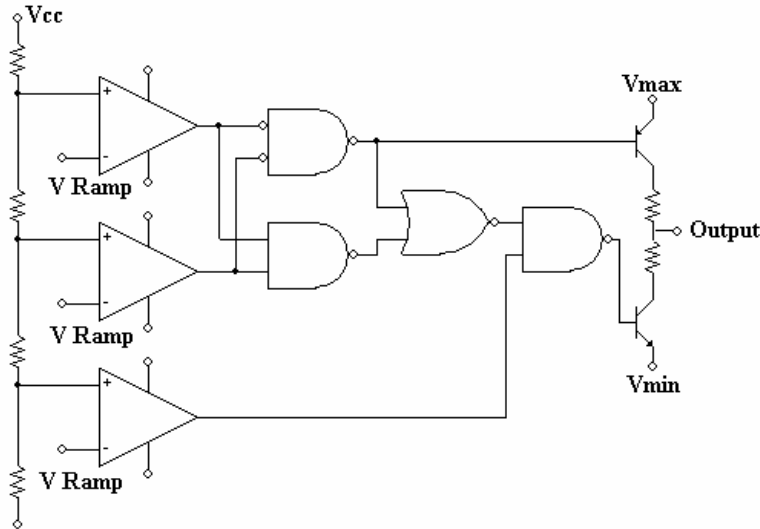
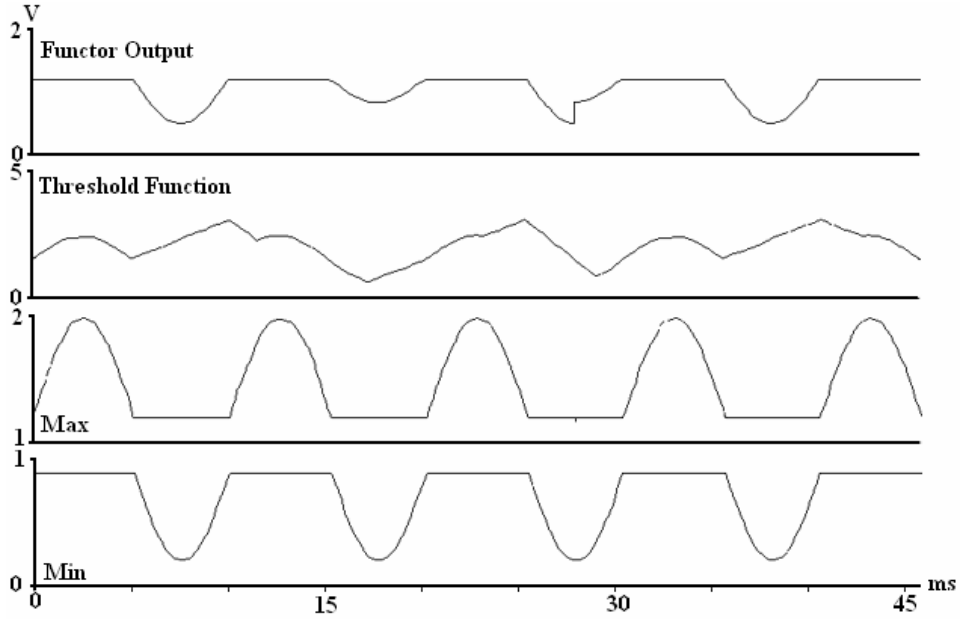
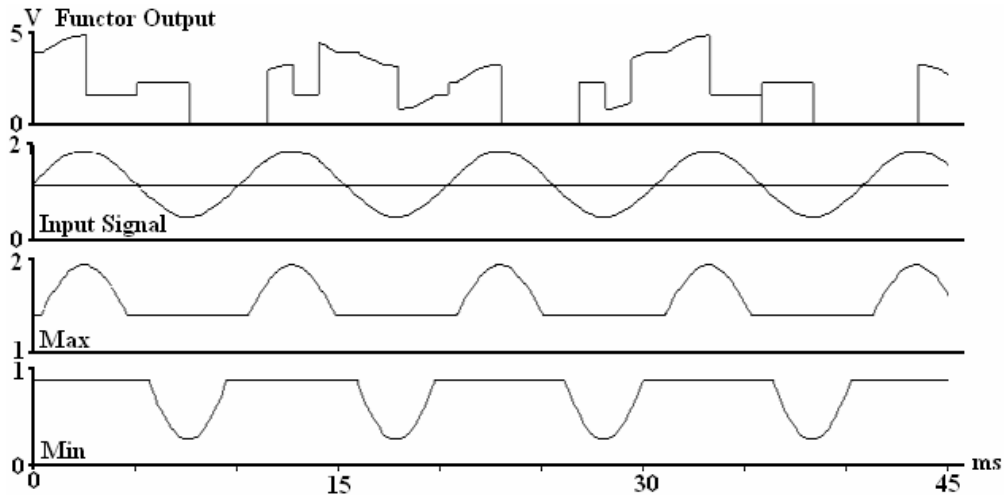

Figure 4. Output selection logic circuit.

The operation of the circuit is the following one: since the voltage divider operates with a fixed signal, the values in the positive input of each comparator are given by values $1/3 V_{cc}$ (C_1), $2/3 V_{cc}$ (C_2) and $3/3 V_{cc}$ (C_3), we have that the comparators will go commuting as the signal ramp increases or decreases its value, which causes that the gates output operates as shown in the following table:

$F(t)=mt$	Output
$0 V_{cc}$	Original signal
$1/3 V_{cc}$	Minimum value of the signal
$2/3 V_{cc}$	Maximum value of the signal
$3/3 V_{cc}$	Null output
$2/3 V_{cc}$	Maximum value of the signal
$1/3 V_{cc}$	Minimum value of the signal
$0 V_{cc}$	Original signal

As it is indicated in the table, as the signal ramp ascends and descends, we have equal output states values for equal ramp signal values. The objective of this table is to indicate the operation sequence, but it is helpful to clarify that the signal that can make the selection of output values is not limited to this signal type. As a sample of dynamic fuzzy logic functor operation, a series of a variable values sequence signals that correspond to the instants shown in the previous table are presented. For a complete operation the outputs obtained are shown in Figure 5. In Figure 5(a), a ramp threshold function and a senoidal input signal are shown. It is clearly shown how the max and the min in time and the output signal of the functor for these conditions are selected. In Figure 5(b), The output signal is shown for the same input but, in it, the threshold function is much more complex; since it is formed by the sum of the ramp and a senoidal, the max and the min are presented. In Figure 5(c), the dynamic fuzzy logic functor response is shown for the same input,, with a complex threshold signal which is the sum of a ramp and a senoidal, the max and the min.



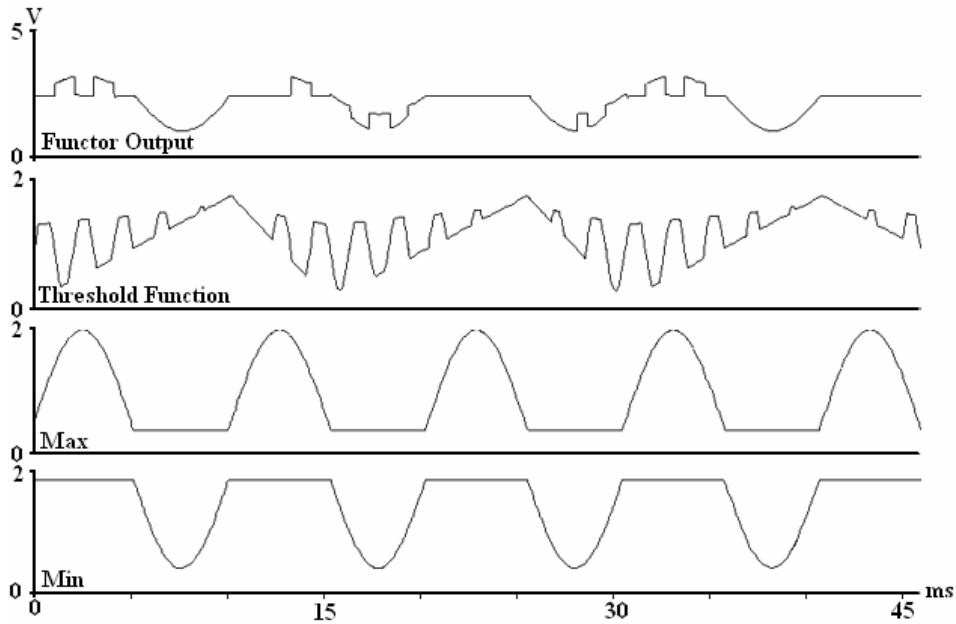

Figures 5. Functor Outputs.

Thinking about the problem in a different way, instead of modifying the threshold function, we will modify the input signal to a more complex form. In Figure 6(a), a ramp threshold function and an a senoidal input signal that is a added with a triangular are shown. There it is shown clearly how the max and min are selected in time and the functor output signal for these conditions. In Figure 6(b), the response of the dynamic fuzzy logical functor is shown for the same threshold function, but with an input that is much more complex since it is formed by the sum of the ramp and a senoidal of greater amplitude. In Figure 6(c), the response of the dynamic fuzzy logical functor is shown for the same threshold function, with an input composed by the sum of a square and a senoidal as well as the response of the max and min operators.

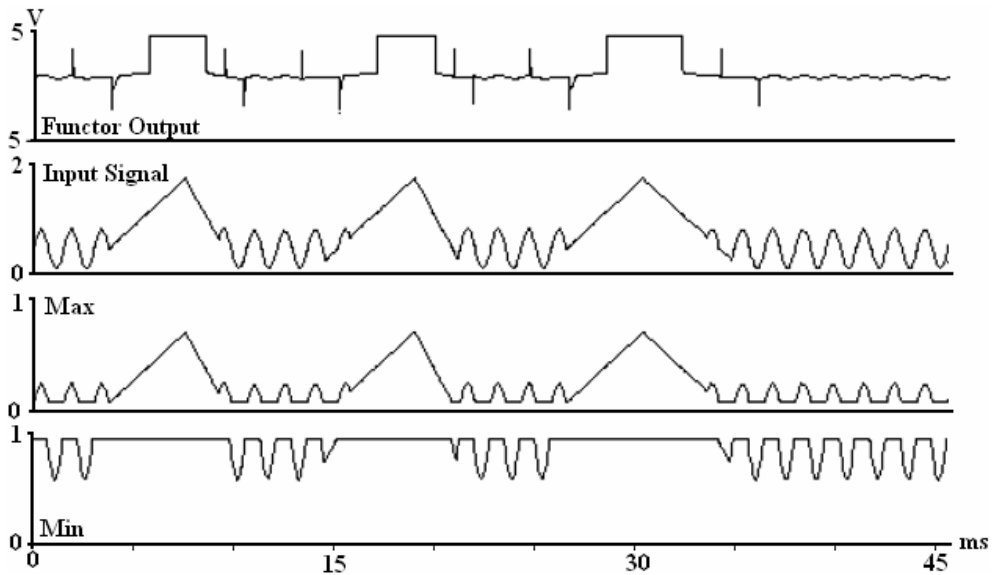

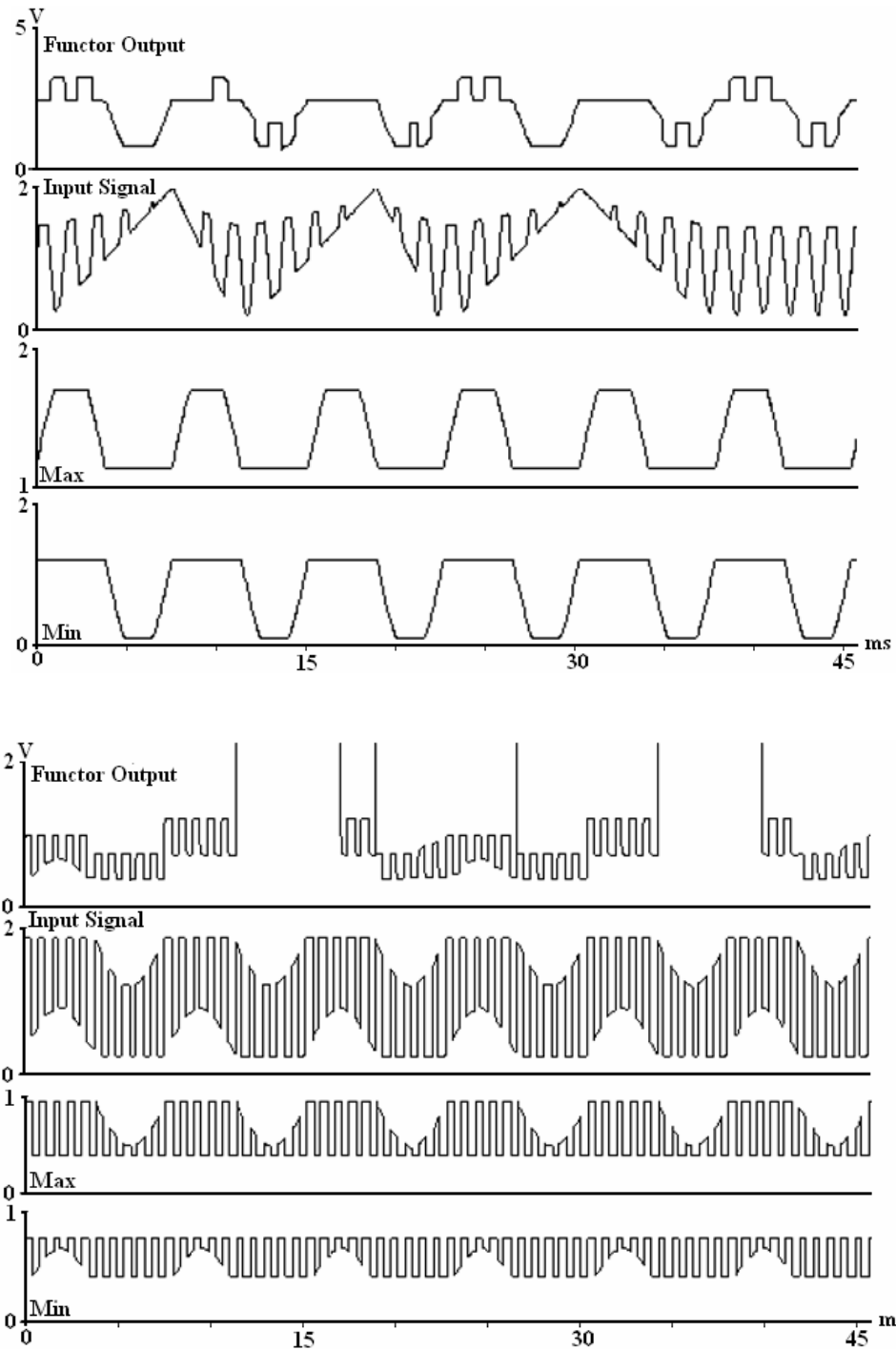

Figure 6. Functor output with triangular threshold function and complex input signal.

In Figure 7, a functor complete schematic diagram is shown.

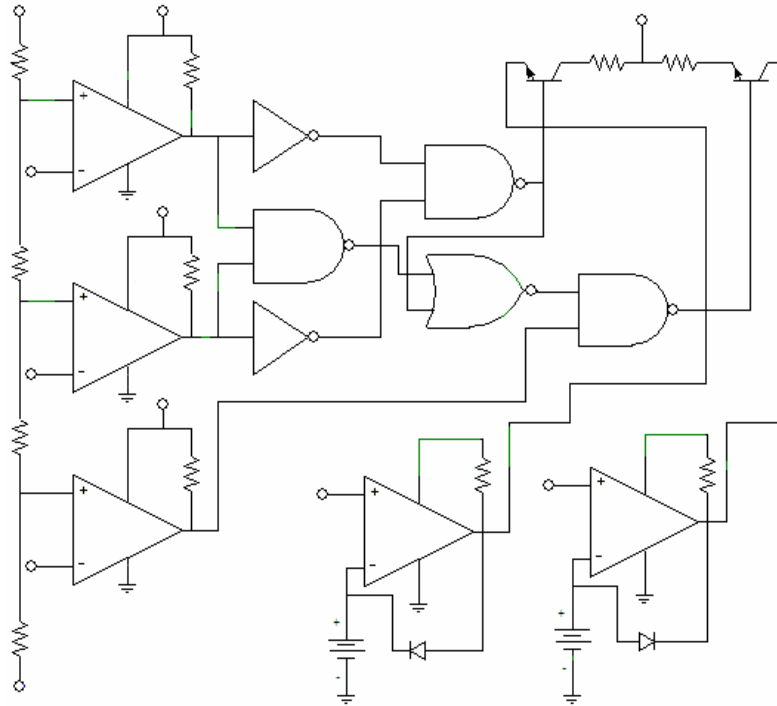

Figure 7. Functor complete schematic diagram

5. REFERENCES

- [1] J.L. Pérez, F. Lara, A. Miranda, A. Herrera, S. Quintana, M. Bañuelos, W. Martínez, J. Castillo, A. Padrón, A. Garcés. "Dinamic Fuzzy Sets". Advances in Artificial Intelligence and Engineering Cybernetics. Vol III ISBN 0-921836-62-7, Editor George E. Lasker. Published by International Institute for Advanced studies in Systems Research and Cybernetics. Pag. 39-43. 1998.
- [2] Pérez J.L., A. Miranda, A. Garcés. "Time and Threshold Dependent Logic Operators" Advances in Artificial Intelligence and Engineering Cybernetics. Editor George E. Lasker. Published by International Institute for Advanced studies in Systems Research and Cybernetics. 1999, IX, pp 6-10
- [3] Pérez S. J.L., Lara F., Herrera A., Bañuelos M., Quintana S., Castillo J., Martínez W., Padrón A., Garcés A., Prieto R. *Dynamic Approximate Reasoning*. "Advances in Artificial Intelligence and Engineering Cybernetics" Editor George E. Lasker. Published by International Institute for Advanced studies in Systems Research and Cybernetics.
- [4] J.L. Pérez S., A. Miranda, A. Garcés, A. Herrera, S. Quintana, J. Castillo, M. Bañuelos, A. Padrón, R. Prieto. An Electronic Implementation of Logic Functor. Instrumentation & Development. 5 1 pp. 39-47 2001